

Valley Grinding TRU-FIT™ Split Bands

Quick Change Out Reduces Costly Downtime

As the saying goes, “Time is money,” and TRU-FIT™ Split Bands from Valley Grinding can save you both.

- Patent No. 5,085,535 locking device allows Split Bands to be installed and removed without having to disassemble heavy shafts and gears.
- By custom manufacturing TRU-FIT™ Split Bands to existing machine specifications, customers can maintain inventory of solid bottoms and avoid expensive machinery modifications
- Superfinished cutting edges reduce friction between bottom band and top splitter – resulting in less blade wear, extended run times, improved cut quality and reduction of dusting.
- Use of Through Hardened, D-2 material improves wear resistance and impact strength for stronger, longer lasting parts.
- Single, Double or Multi Cutting Edges provide maximized slit positions per unit and are adjustable to customer applications.
- By uniquely marking our Split Bands on each side for easy assembly, time consuming corrections when parts are assembled incorrectly can be avoided.

Available in outside diameter sizes from 3" to 12", Valley Grinding TRU-FIT™ Split Bands are precision tested to assure quality and are guaranteed to fit...every time. For the finest product quality, industry expertise and “cutting edge” technology, you can rely on the experts at Valley Grinding.

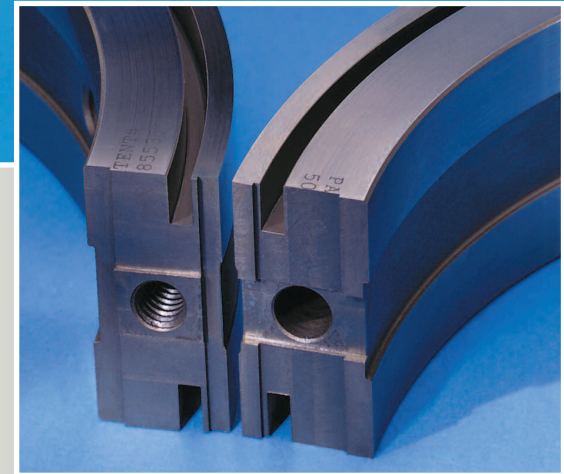

Call today for a **FREE Consultation**
800.950.7675



Leading The Way To A Sharper Future

CORPORATE OFFICE

1717 Hamilton Ct., P.O. Box
246, Little Chute, WI 54140
Phone: 920.788.9131
Toll Free: 800.950.7675
Fax: 920.788.9193

COLUMBUS SERVICE CENTER

2853 Johnstown Rd., Columbus, OH 43219
Phone: 614.418.0118
Toll Free: 866.377.9316
Fax: 614.418.0120

ATLANTA SERVICE CENTER

110 C Shamrock Industrial Blvd., P.O. Box 690,
Tyrone, GA 30290
Phone: 770.487.8959
Toll Free: 770.487.8959
Fax: 770.487.9143

Email: sales@valleygrinding.com • www.valleygrinding.com

HIGH PERFORMANCE TRU-FIT™ SPLIT BANDS

Only Valley Grinding gives you this unique patented locking system

- Locks tight to form a seamless joint
- Locates in two directions
- Prevents lateral and horizontal shifting
- Easy installation, easy removal

Split Bands improve slitter performance

- Reduces frequency of complete anvil changes
- Speeds change-over time
- Keeps process running longer, sharper, cleaner
- Reduces spare anvil inventory

Valley Grinding gives you unmatched quality

- Superfinished to precise tolerances
- Fast order turn-around
- Timely delivery
- Quality guaranteed—a perfect fit every time

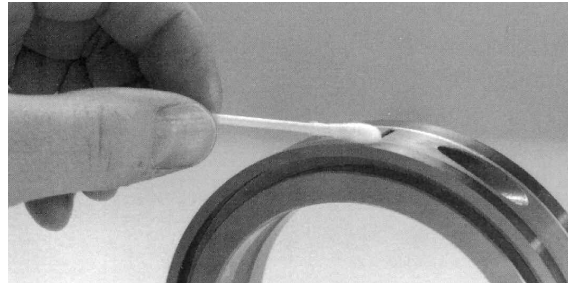

The Swab Test

The patented locating system of the Tru-Fit Split Band provides a seamless edge everytime. We use precision instruments to check the final fit of all finished bands. However, you can use a cotton swab for a quick in-shop test. Rub a swab across a Tru-Fit Split Band seam. The light cotton fibers won't catch or snag. Try this test on any other split band type product. You'll soon see why Valley Grinding quality is guaranteed.

DOUBLE-EDGE SPLIT BOTTOM BANDS

SLITTER OUTSIDE DIA.	A	B	C	D	E	F*
3' MIN THRU 4-1/2"	CUST SPEC	.650 MIN 2.50 MAX	.090 TO .250	CUST SPEC	.550 MIN	.450 MIN. WALL
OVER 4-1/2" THRU 6"	CUST SPEC	.700 MIN 3.00 MAX	.125 TO .250	CUST SPEC	.600 MIN	.550 MIN. WALL
OVER 6" THRU 12"	CUST SPEC	.825 MIN 3.50 MAX	.125 TO .250	CUST SPEC	.725 MIN	.725 MIN WALL

*FOR SLITTERS OUTSIDE OF LISTED VARIABLES, PLEASE CALL SALES.

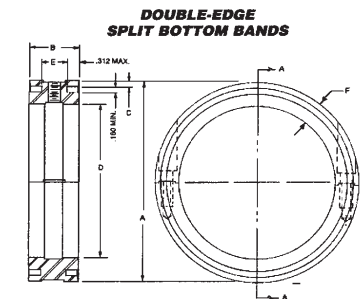

MULTI-GROOVE SPLIT BOTTOM BANDS

SLITTER OUTSIDE DIA.	A	B	C**	D	E	F*
3' MIN THRU 4-1/2"	CUST SPEC	1.300 MIN 2.550 MAX	CUST SPEC	CUST SPEC	.550 MIN	.450 MIN. WALL
OVER 4-1/2" THRU 6"	CUST SPEC	1.350 MIN 3.000 MAX	CUST SPEC	CUST SPEC	.600 MIN	.550 MIN. WALL
OVER 6" THRU 12"	CUST SPEC	1.475 MIN 4.000 MAX	CUST SPEC	CUST SPEC	.725 MIN	.725 MIN WALL

*FOR SLITTERS OUTSIDE OF LISTED VARIABLES, PLEASE CALL SALES.

**NUMBER OF CUTTING EDGES AVAILABLE WILL VARY WITH SPACING REQUIREMENTS

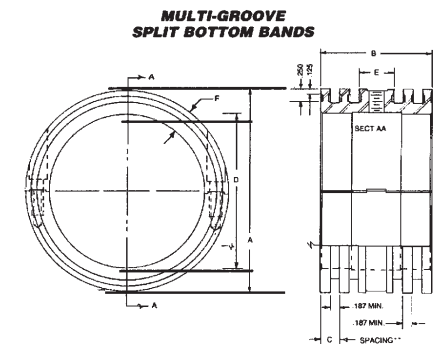

Call today for a FREE Consultation
800.950.7675



Leading The Way To A Sharper Future

CORPORATE OFFICE

1717 Hamilton Ct., P.O. Box
246, Little Chute, WI 54140
Phone: 920.788.9131
Toll Free: 800.950.7675
Fax: 920.788.9193

COLUMBUS SERVICE CENTER

2853 Johnstown Rd., Columbus, OH 43219
Phone: 614.418.0118
Toll Free: 866.377.9316
Fax: 614.418.0120

ATLANTA SERVICE CENTER

110 C Shamrock Industrial Blvd., P.O. Box 690,
Tyrone, GA 30290
Phone: 770.487.8959
Toll Free: 770.487.8959
Fax: 770.487.9143

Email: sales@valleygrinding.com • www.valleygrinding.com